

# F 300 VO-L

VOLANO

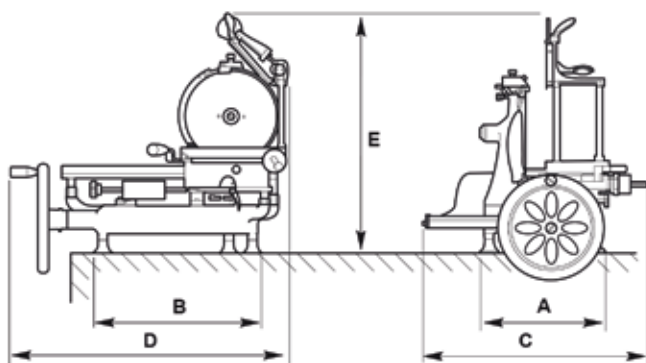

FABBRICA AFFETTATRICI CAVARIA



F 300 VO-L

A mm	330
B mm	420
C mm	545
D mm	750
E mm	720
kg	44

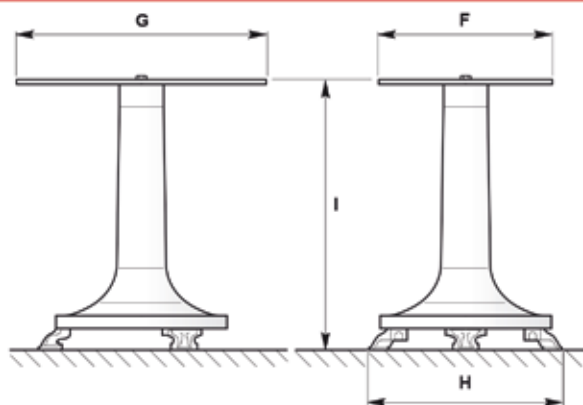

Piedistallo

F mm	400
G mm	500
H mm	650
I mm	800
kg	46

 L'affettatrice modello **300 VO-L** costruita in alluminio e parti in acciaio, con una verniciatura a fuoco, ha il vantaggio di una rapida pulizia ed assoluta igiene. La macchina è a funzionamento manuale e può quindi lavorare anche in luoghi privi di energia elettrica. L'affilatoio incorporato semplifica il lavoro dell'operatore mantenendo efficiente il taglio perfetto del prodotto. Dotata di protezione ad anello attorno alla lama a norme CE, la **300 VO-L** è robusta, durevole ed affidabile.

**CARATTERISTICHE TECNICHE**

		F 300 VO-L	
Ø Lama	mm	300	100 CR6
Spessore di taglio	mm	0+2,5	10 Posizioni
Taglio utile: L x H		230 x 180	

Garanzia: 2 anni.

 Made of aluminium with parts of steel and finishing, the **300 VO-L** slicer permits rapid cleaning and meets the most demanding sanitation requirements. This unit is fully hand-operated and does not need to be connected to the mains. The blade sharpener is built-in for effective and sharp cutting. Equipped with protection ring around its blade to CE Standards, the **300 VO-L** is a sturdy, long-lasting and effective slicing unit.

**SPECIFICATIONS**

		F 300 VO-L	
Ø Blade	mm	300	100 CR6
Cut thickness range	mm	0+2,5	10 Cutting positions
Cut: L x H	mm	230 x 180	

Warranty: 2 years.

 Fabriquée en aluminium avec pièces en acier et laquée, la trancheuse **300 VO-L** garantit hygiène absolue et nettoyage rapide. Son fonctionnement complètement manuel la rend indispensable surtout quand il n'y a pas de courant électrique. Un affûteur incorporé simplifie le travail de l'opérateur car le tranchant de la lame est toujours parfait. **300 VO-L** est équipée d'une bague de protection autour de la lame selon les normes CE. C'est une machine robuste, indestructible et fiable.

**SPECIFICATIONS**

		F 300 VO-L	
Ø lame	mm	300	100 CR6
Épaisseur de coupe	mm	0+2,5	10 Positions de coupe
Surface de coupe: L x H	mm	230 x 180	

Garantie: 2 années.

 Die Aufschnittmaschine Model **300 VO-L**, hergestellt aus Aluminium und Stahlteilen mit Feuerlackierung in, hat den Vorteil einer schnellen und leichten Reinigung und damit der absoluten Hygiene. Die Maschine wird von Hand betrieben und kann folglich auch in Räumen ohne Strom arbeiten. Die eingebaute Schleifvorrichtung vereinfacht die Arbeit des Bediennenden und hält den Schnitt der Ware perfekt. Versehen mit einem Ringschutz um das Messer nach EG-Richtlinien, ist die **300 VO-L** robust, zuverlässig und von langer Lebensdauer.

**TECHNISCHE EIGENSCHAFTEN**

		F 300 VO-L	
Ø Klingendurchmesser	mm	300	100 CR6
Schnittstärke	mm	0+2,5	10 Schnittposition
Nutzschnitt: L x H	mm	230 x 180	

Garantie: 2 Jahre.

